



# Mobile Carts & Stands

Innovative solutions for collaborative technologies



# Elite Series

The ELT series of mobile display carts and stands offer the ultimate style and comprehensive design for today's technology. The elite series is ideal for collaboration environments needing a robust videoconferencing solution and may be customized to meet specialized needs. Made of 100% steel construction, the carts and stands support both single and dual displays.

## ELT-1500

The ELT-1500 is the perfect stand for single or dual displays. The stand offers ample storage space easily accessed via the front panel or the locked rear door. The integrated speaker module provides improved audio capabilities.

**Adjustable camera shelf**  
and mounting position  
allows camera to be above  
or below display.

**Universal display mount**  
supports single or dual  
displays.

**Removable front panel**  
allows easy access to the  
cabinet.

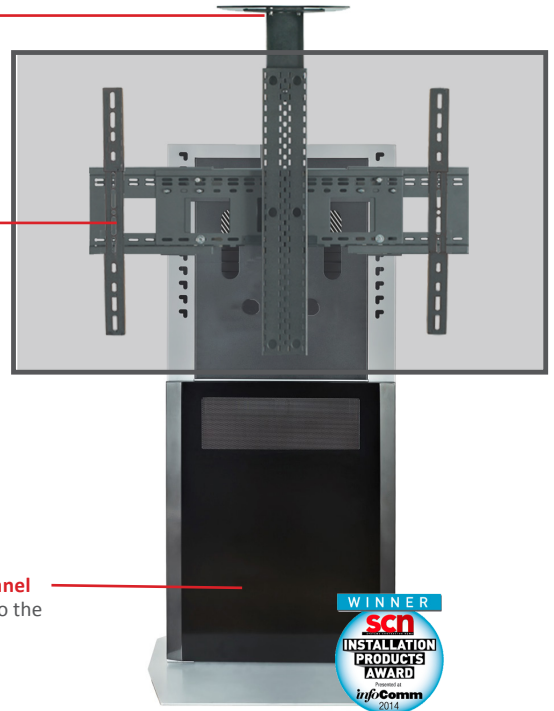

**Amplivox speaker module**  
integrated for improved audio  
capabilities.

**Lockable hinged door**  
on back provides safe  
accessibility to equipment.

**Single and dual gang knockouts**  
on back provide quick wall plate  
installation.



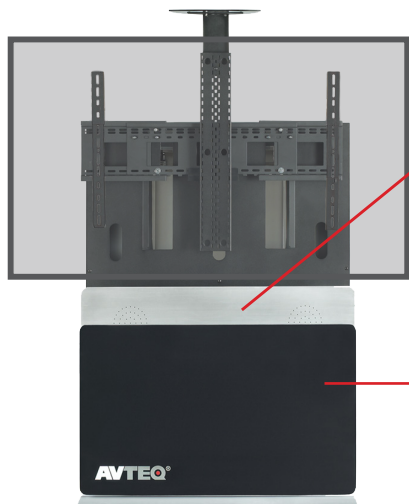

**M-Audio speaker set** is integrated for enhanced audio capabilities.



**Vertical rack space** within slide-out drawer for 19"D 10RU rack. Front panel made of tempered, glossy-black glass.

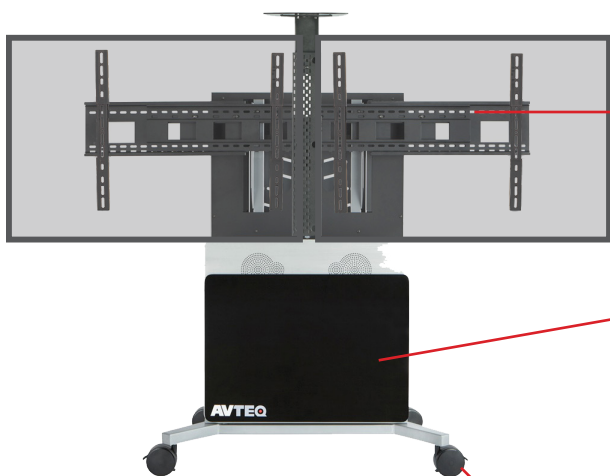

**Universal display mount** supports single or dual displays.



**Tempered, gloss-black glass door** provides quick access to the technology rack space.

**5" lockable casters** provide ease of movement across any surface. Optional 6" casters provide enhanced stability for larger displays.

## ELT-2000

The ELT-2000 offers a flexible and stable solution for single or dual displays. An optional base provides enhanced stability of displays larger than 90". An integrated M-Audio speaker set enhances the audio capabilities of your videoconferencing technology.

## ELT-2100

The ELT-2100 mobile cart provides the style and flexibility for multi-use corporate, education and government environments. The ELT-2100 supports single or dual displays making this cart the ideal solution for today's technology.

## SPECIFICATIONS

PRODUCT	DIMENSIONS	RACK SPACE	LOAD CAPACITY	DISPLAY SIZE	PART NUMBER
ELT-1500	59"H x 29"W x 9"D		150 lbs	Single display up to 60"	ELT-1500S
				Dual displays up to 42"	ELT-1500L
ELT-2000	58 1/2"H x 43"W x 18 1/2"D	10RU	400 lbs	Single display up to 80"	ELT-2000S
				Single display up to 90"	ELT-2000-EB
				Dual displays up to 70"	ELT-2000L
ELT-2100	64"H x 48"W x 32"D	10RU	400 lbs	Single display up to 80"	ELT-2100S
				Single display up to 90"	ELT-2100-EB
				Dual displays up to 70"	ELT-2100L

# RPS Series

The RPS series of mobile display carts provide a wide range of features and capabilities designed to meet the needs of today's collaborative workspaces. RPS carts support both single and dual displays. All carts are made of 100% steel construction and offer custom options.

## RPS-500

The RPS-500 mobile display cart has sleek contemporary lines and supports single or dual displays. The RPS-500 is an ideal choice for all-in-one interactive displays.

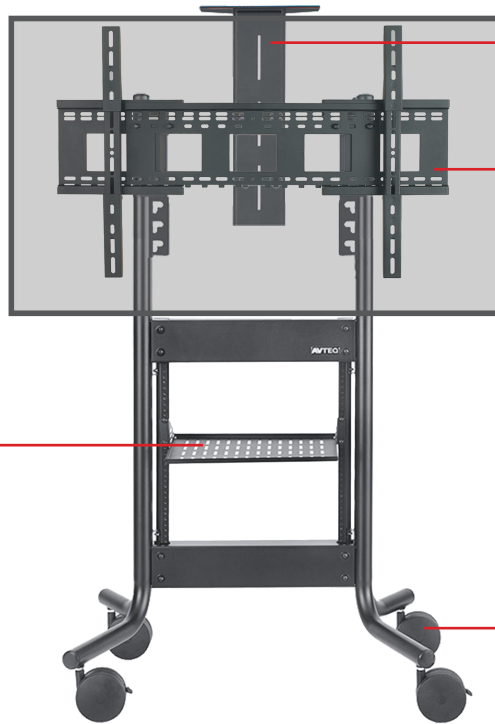

**Adjustable camera shelf** supports a wide range of videoconferencing cameras above or below the display.

**Display mount** supports single or dual displays. A specialized mount is available for the Cisco Webex Board.

**Rack mounted shelf** provides easy access to technology.

**5" lockable casters** make it easy to move the cart. Optional 6" casters provide enhanced stability of larger displays.

## RPS-200

The RPS-200 is a light-weight mobile cart and is an affordable option for a single display up to 60".

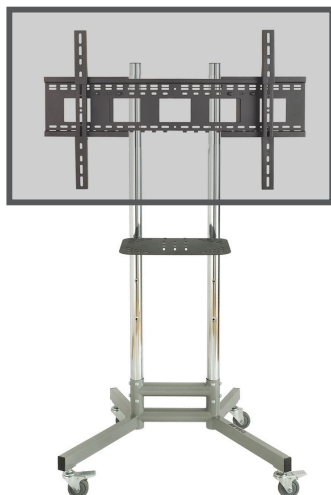

## RPS-400

The RPS-400 is a cost efficient cart with sleek classic lines. The cart includes height adjustable camera shelf and supports a single display up to 55".

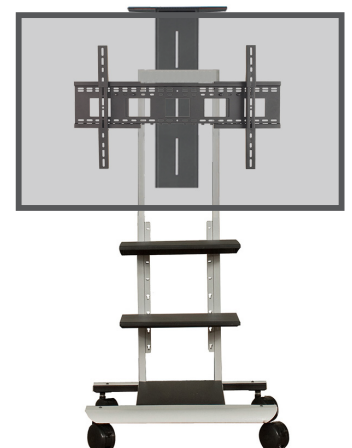

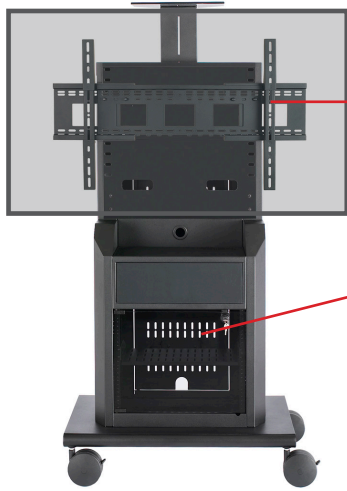

**Universal display mount** supports single or dual displays up to 60”.

**Tempered, tinted locking glass front door** and two lockable rear doors provides easy access to the internal storage for your technology.

## RPS-800

The RPS-800 display cart combines a small footprint with the functionality and flexibility desired in a videoconferencing cart solution.

The RPS-800 supports single or dual displays up to 60” and provides 9RU of rack space for your technology needs.



**Integrated AmpliVox® speaker module** enhances audio capabilities.

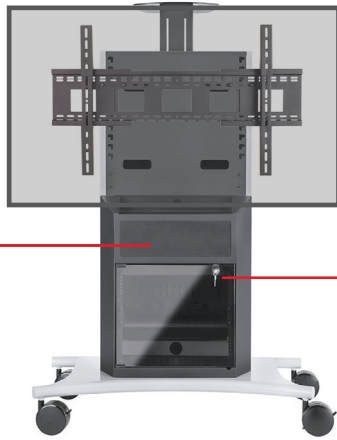

**Two rear doors** for quick access to technology and cable management features.

## RPS-1000

The RPS-1000 is the perfect mobile solution for education and corporate environments utilizing large displays up to 70”. The RPS-1000 offers either 12” or 15.5” rack space to address varying technology specifications.

The RPS-1000, along with all of the RPS series, is customizable.

## SPECIFICATIONS

PRODUCT	DIMENSIONS	RACK SPACE	RACK	LOAD CAPACITY	DISPLAY SIZE	PART NUMBER
RPS-200	60”-71”H x 32”W x 29”D			150 lbs	Single display up to 60”	RPS-200
RPS-400	51”H x 24”W x 21”D			150 lbs	Single display up to 55”	RPS-400
RPS-500	61”H x 37”W x 26”D	10RU		250 lbs	Single display up to 70”	RPS-500S
					Dual displays up to 60”	RPS-500L
	61”H x 48”W x 26”D				55” Cisco Webex Board	RPS-500-CSB55
	61”H x 62”W x 26”D				70” Cisco Webex Board	RPS-500-CSB70
RPS-800	60”H x 33”W x 23”D	9RU	15” D	300 lbs.	Single display up to 60”	RPS-800S
					Dual displays up to 60”	RPS-800L
RPS-1000	62”H x 44”W x 24”D	8RU	12” D	300 lbs	Single display up to 70”	RPS-1000S
			15.5” D	300 lbs	Single display up to 70”	RPS-1000S-E
			12” D	350 lbs	Dual displays up to 70”	RPS-1000L
			15.5” D	350 lbs	Dual displays up to 70”	RPS-1000L-E

# Height Adjustable Solutions

## DynamiQ™ RPS-500

The height adjustable DynamiQ RPS-500 mobile display cart is an ideal solution for touch panel displays. The spring-weighted, height adjustable mount allows the display to easily glide up and down with a feather-light touch of the finger.

The DynamiQ RPS-500 supports a wide variety of all-in-one displays, making it perfect for collaborative work spaces.

**Height adjustable DynamiQ 400 mount** allows the display to glide up and down with a feather-light touch of the finger.

**Rack mounted shelf** allows for easy access to technology.

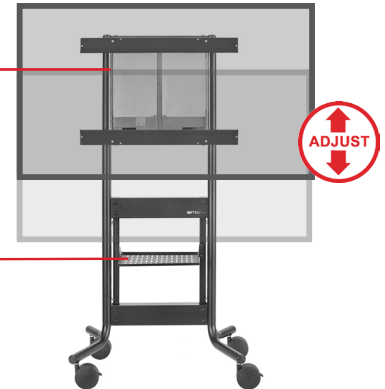

## DynamiQ™ Wall Stand

The DynamiQ™ Wall Stand is a height adjustable wall-mounted stand—perfect solution for interactive displays in the classroom, library, training center or board room. The DynamiQ™ Wall Stand provides your choice of a motorized or spring-adjusted display lift functionality.

The spring-weighted technology mount requires no electricity and allows the display to move up and down with a simple touch of the finger.

The motorized mount, powered by an electric lift, allows you to safely and quietly raise and lower single displays up to 300 lbs. The control panel, located on the side of the stand, includes two preset heights or can be controlled with the touch of a button.

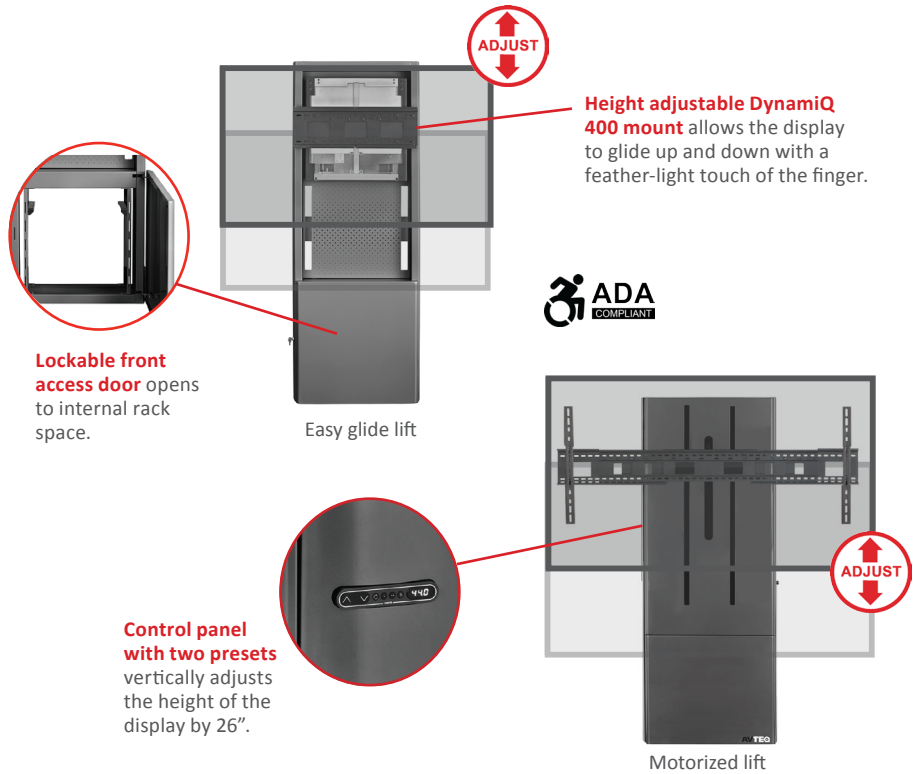

**Lockable front access door** opens to internal rack space.

Easy glide lift

**Height adjustable DynamiQ 400 mount** allows the display to glide up and down with a feather-light touch of the finger.

**Control panel with two presets** vertically adjusts the height of the display by 26".

Motorized lift

## SPECIFICATIONS

PRODUCT	DIMENSIONS	LIFT	VERTICAL ADJUST	RACK SPACE	LOAD CAPACITY	DISPLAY SIZE	PART NUMBER			
DynamiQ RPS-500	74"H x 40"W x 30"D	Easy glide	15.75"	10RU	Up to 83.6 lbs	Single display	RPS-500-40			
					83.6 - 145 lbs.	Single display	RPS-500-70			
					145.2 - 198 lbs	Single display	RPS-500-90			
	74"H x 48"W x 30"D							Up to 145 lbs	55" Cisco Webex Board	RPS-500-BB-CSB55
	74"H x 62"W x 30"D							Up to 198 lbs	70" Cisco Webex Board	RPS-500-BB-CSB70
DynamiQ Wall Stand	79"H x 29"W x 9"D	Easy glide	15.75"	3RU	198 lbs	Based on weight	D-WMS-BB			
	79"H x 48"W x 9"D					55" Cisco Webex Board	D-WMS-BB-CSB55			
	79"H x 62"W x 9"D					70" Cisco WebexBoard	D-WMS-BB-CSB70			
	79"H x 34"W x 9"D	Motorized	26"	300 lbs	Based on weight	D-WMS				

## DynamiQ™ Touch Panel Cart

The DynamiQ™ Touch Panel Cart provides maximum configuration for any large format display by easily adjusting it from a standard cart configuration to a drafting table to a table top.

The easy access control panel is mounted on the side and includes two preset configurations. The DynamiQ™ cart provides stability and flexibility making it a perfect solution for large displays.

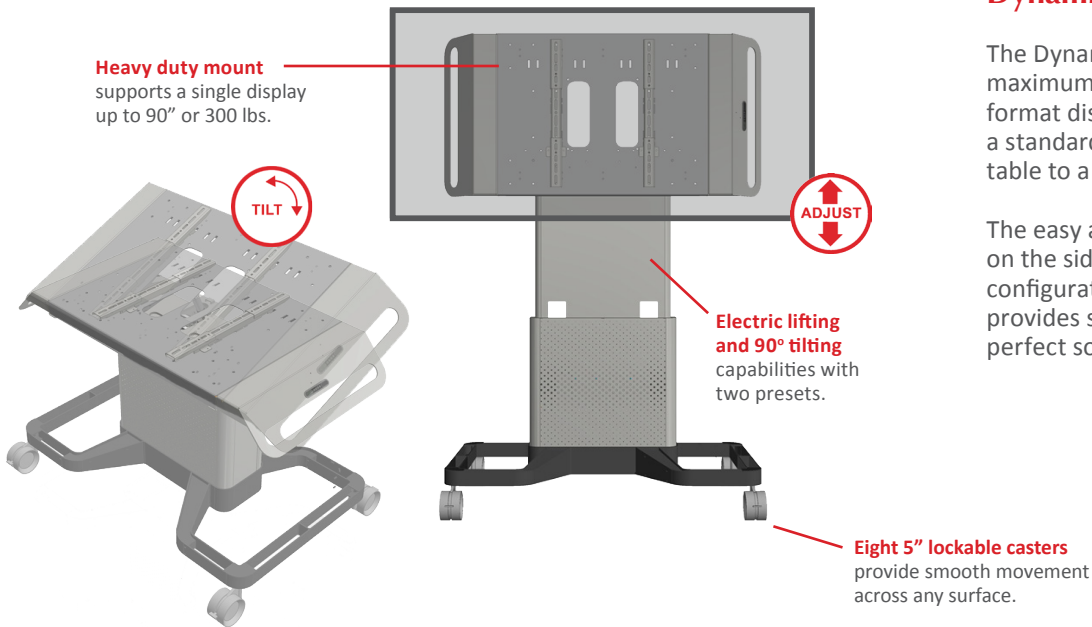

## RPX

The RPX mobile display cart is designed for large interactive touch panel displays. The slim profile of the RPX allows for plenty of unobstructed access to the workable surface of the display making it ideal for interactive learning centers and collaborative work spaces.

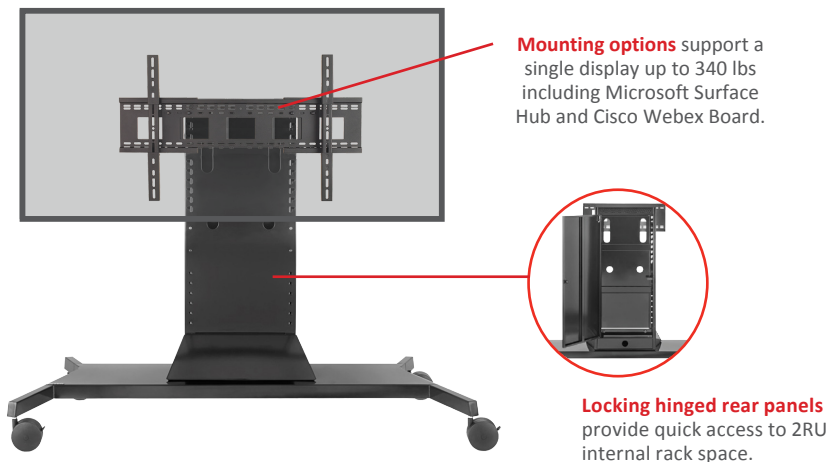

## SPECIFICATIONS

PRODUCT	DIMENSIONS	LIFT	VERTICAL ADJUST	RACK SPACE	LOAD CAPACITY	DISPLAY SIZE	PART NUMBER
DynamiQ Touch Panel Cart	56"-80"H x 65"W x 35"D	Motorized	16.94"		300 lbs	Single display up to 90"	D-TPC-S
RPX	59"H x 29"W x 20"D			2RU	340 lbs	Single display up to 98"	RPX
	59"H x 62"W x 20"D					70" Cisco Webex Board	RPX-CSB70
	59"H x 62"W x 20"D					84" Microsoft Surface Hub	RPX-SH84

# Telemedicine Carts

## TMP-200

The lightweight TMP-200 telemedicine cart may be customized to meet the needs of your medical facility. Its slim profile and easy rollabout design make it ideal for use in clinics and medical offices with multiple exam rooms.

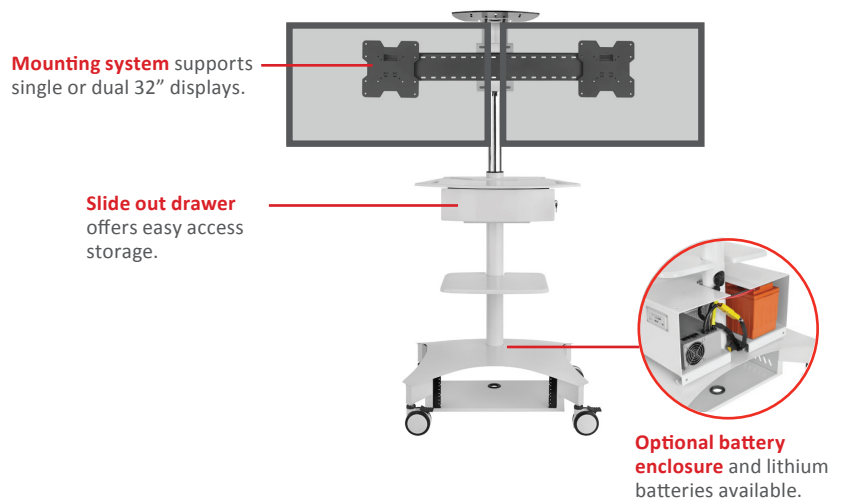

## TMP-600

The TMP-600 telemedicine cart comes with 16RU of ample secure storage to accommodate essential medical equipment. Its large 6" casters make it easy to move through a clinic or medical facility.

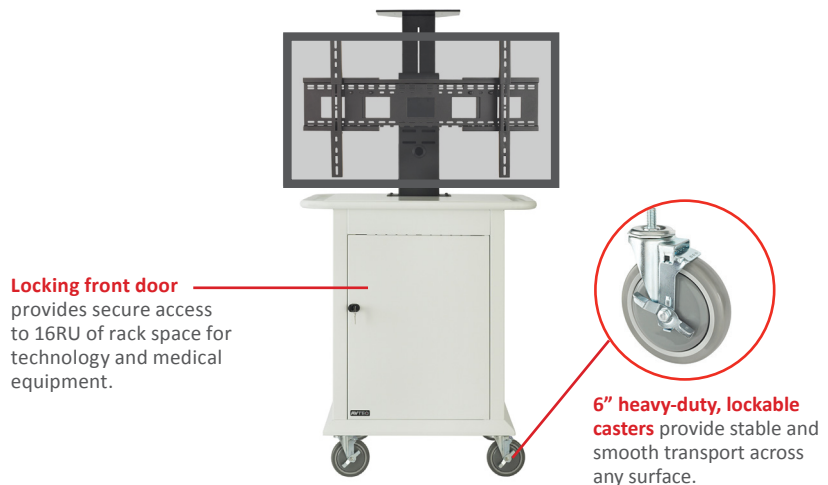

### SPECIFICATIONS

PRODUCT	DIMENSIONS	RACK SPACE	LOAD CAPACITY	SINGLE DISPLAY SIZE	DUAL DISPLAY SIZE	PART NUMBER
TMP-200	61"H x 29"W x 24"D	2RU	200 lbs	32"	32"	TMP-200
						TMP-200-ENC
TMP-600	69"H x 37"W x 28"D	16RU	200 lbs	42"	32"	TMP-600



Call 800.285.8315 or visit AVTEQ.net

