



RPS 500

Items Included

A Upright x2	B Support x2	C Union x2	D Screen mount x1	E Shelf x1
F With brake x2 Without brake x2	G Acrylic Platform x1	H Camera Support x1	i Lacing bars x2	
J Socket Flat Head x4	K 5/16" (x12)	L Socket Button Head 5/16" x 3/4" (x12)	M Socket M6 x 15mm (x4)	N blind nut 1/4" (x 4)
O Socket Button Head 1/4" x 3/4" (x6)	P 1/4" (x4)	Q 1/4" (x8)	R 1/4" (x4) cage nut	S Multi Wrench x1 1/4" Allen x 1 3/16" Allen x 1

1

Multi Wrench

Attach casters (F) to body (A).
Note: Casters with brakes should be assembled on front.

2

Slide horizontal braces (C) to each of the uprights (A)

1/4" Allen

3

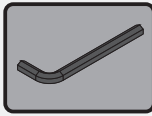

1/4" Allen

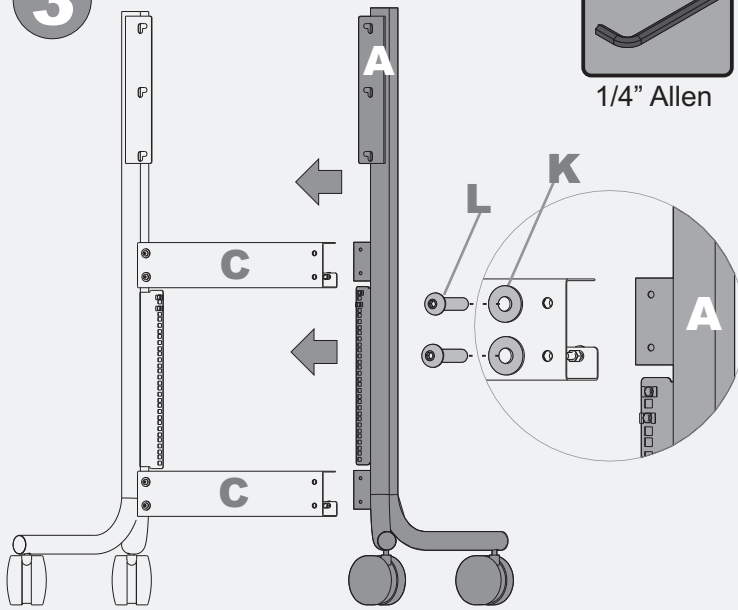

Attach the braces (C) to the uprights (A)

4

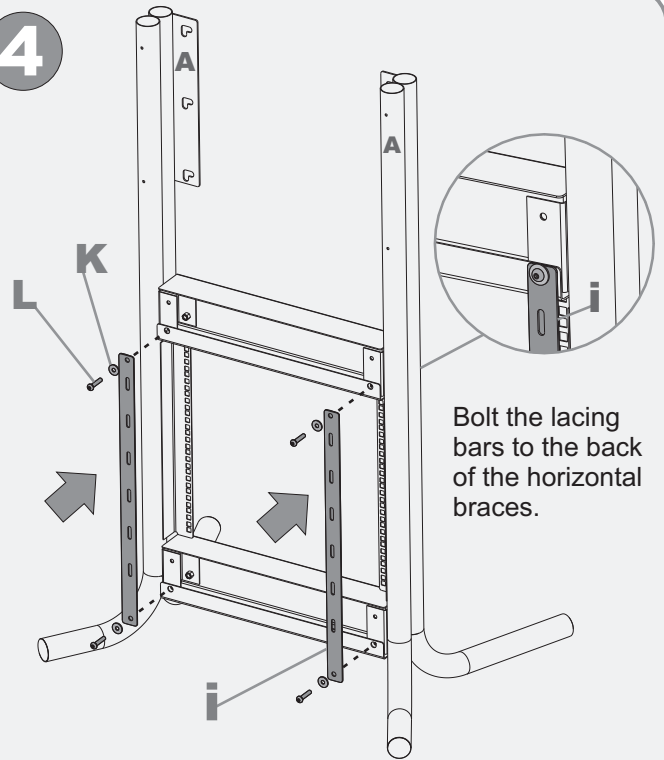

Bolt the lacing bars to the back of the horizontal braces.

5

M

Socket
M6 x 15mm (x4)

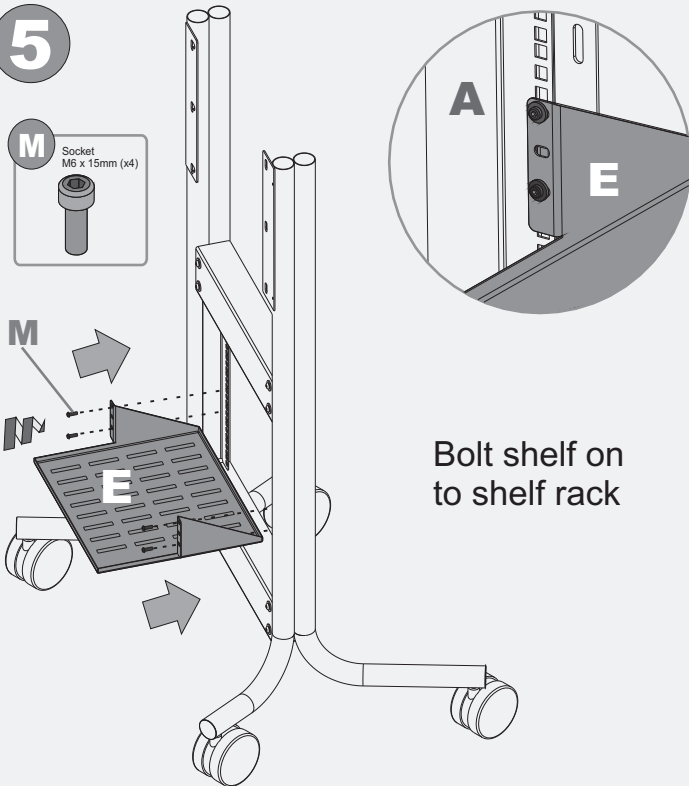

Bolt shelf on to shelf rack

6

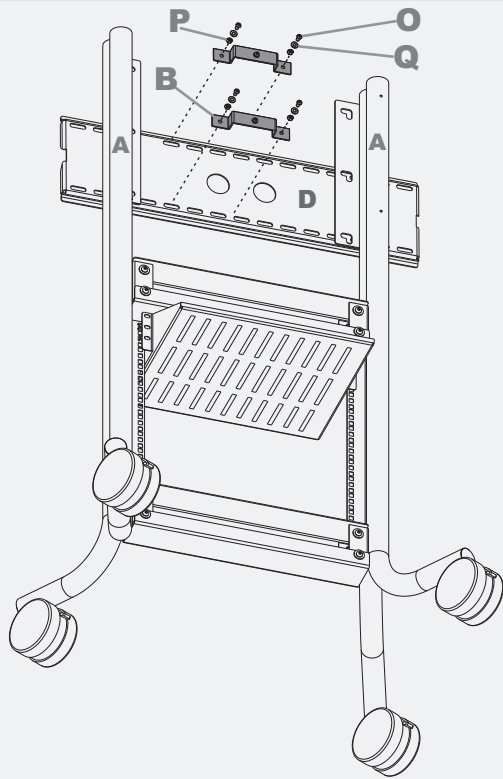

Attach screen support (D)
to body (A)

NOTE: See instructions inside
screen support box to mount
flat screen on cart. please
secure the flat screen to the
cart at desired height before
moving on to step 7

7

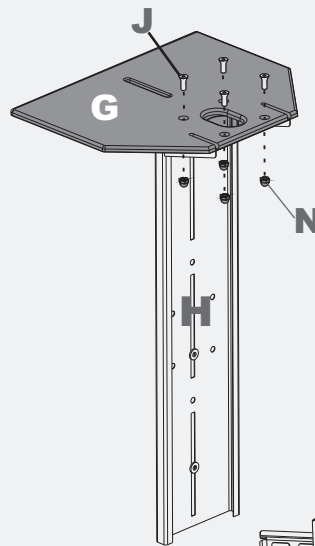
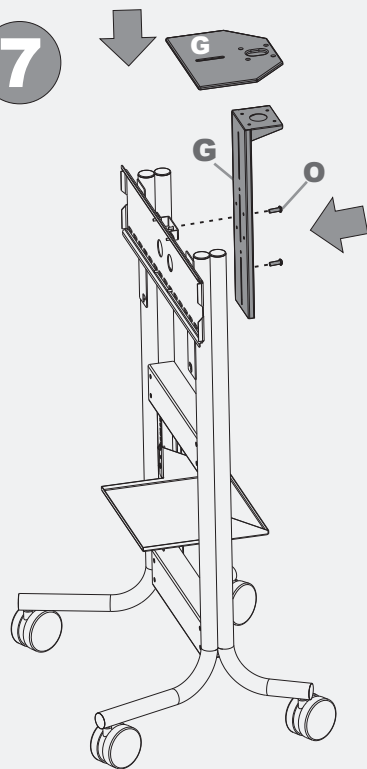

Attach acrylic (G) to
bracket (H) then attach
bracket (H) to body (A)
at desired height.

