

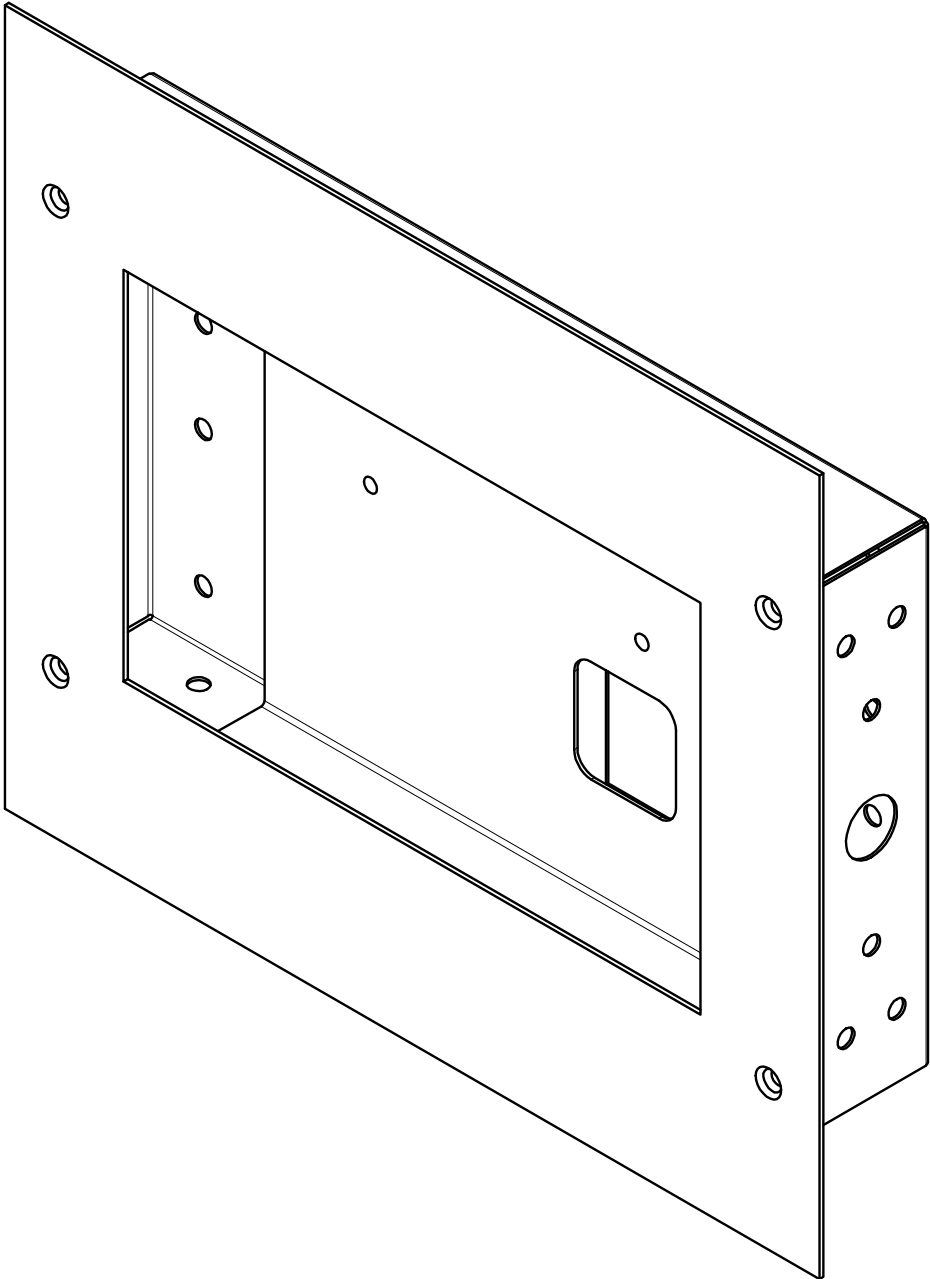

Install Guide

CN-WMP



1

A) Slide the touch panel into the "U" shaped channel on the back of the face plate in front of the flange.

B) Tighten 1/4-20 screws on flange until they touch the back of the panel. Do not overtighten. The touch panel should sit in the bottom of the channel in the flange.

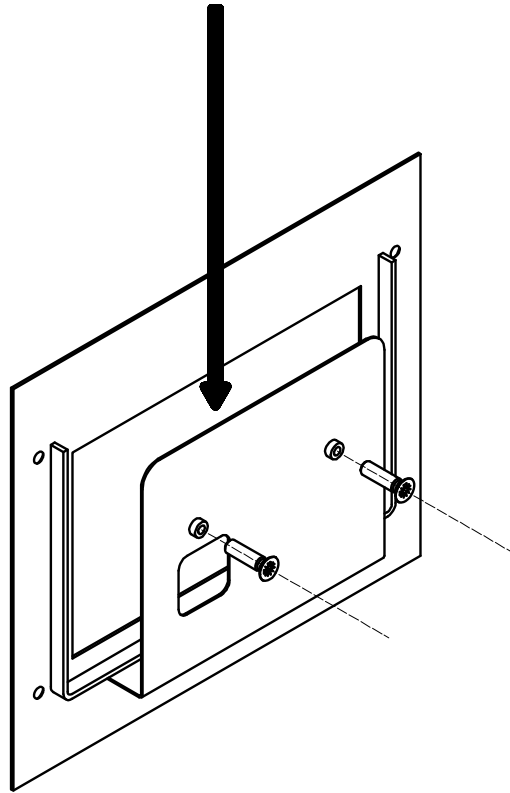

2

Place the wall box in the wall. Secure with either wall anchors on the front flanges or directly to a stud.

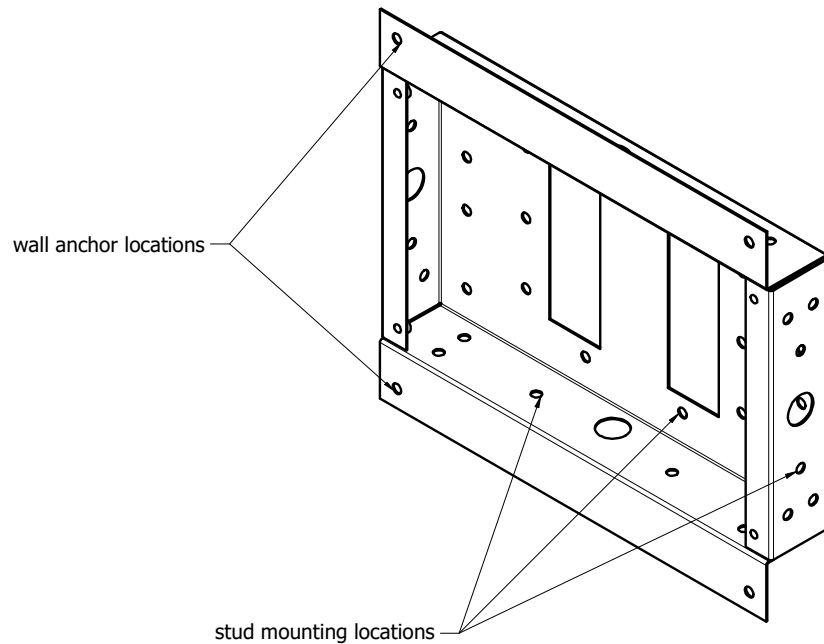

3

Slide the face plate into the wall box and secure with four 1/4-20 screws

