

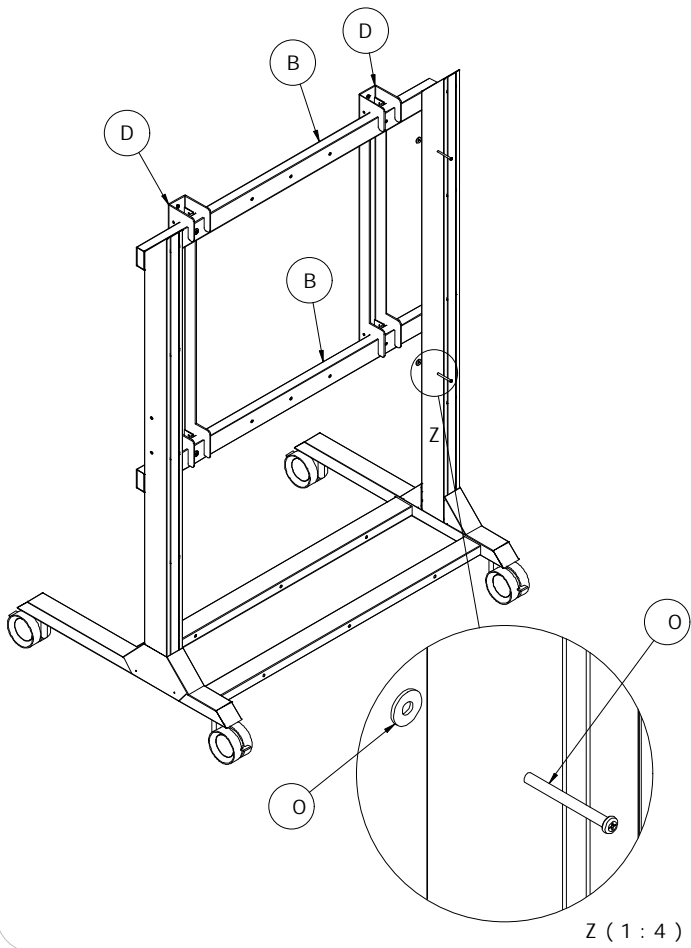





4 Hook the bracket to the front union and secure with screw and washer.



5 Attach the base to the bottom union with screws and washer.

