

PARTS LIST			
ITEM	PART NUMBER	QTY	COLOR
1	PI0294A012 Tapa lamina inferior V01	1	NEGRO MICRO
2	PI0294A005 Travesaño trasero superior V00	1	NEGRO MICRO
3	PI0294A007 Rack V00	2	NEGRO LISO
4	PI0294A009 Madera lateral derecho V00	1	
5	PI0294A010 Madera superior V00	1	
6	PI0294AD016 Omega	2	NEGRO MICRO
7	PI0294A008 Madera lateral izquierdo V00	1	NEGRO MICRO
8	PI0294ASA002 Soldadura marco lateral izquierdo V00	1	NEGRO MICRO
9	PI0294ASA001 Soldadura marco lateral derecho V00	1	NEGRO MICRO
10	PI0294A014 Travesaño frontal V00	2	NEGRO MICRO
11	PI0294A004 Trabesaño trasero inferior V00	1	NEGRO MICRO
12	PI0294A006 tapa trasera V00	1	NEGRO MICRO

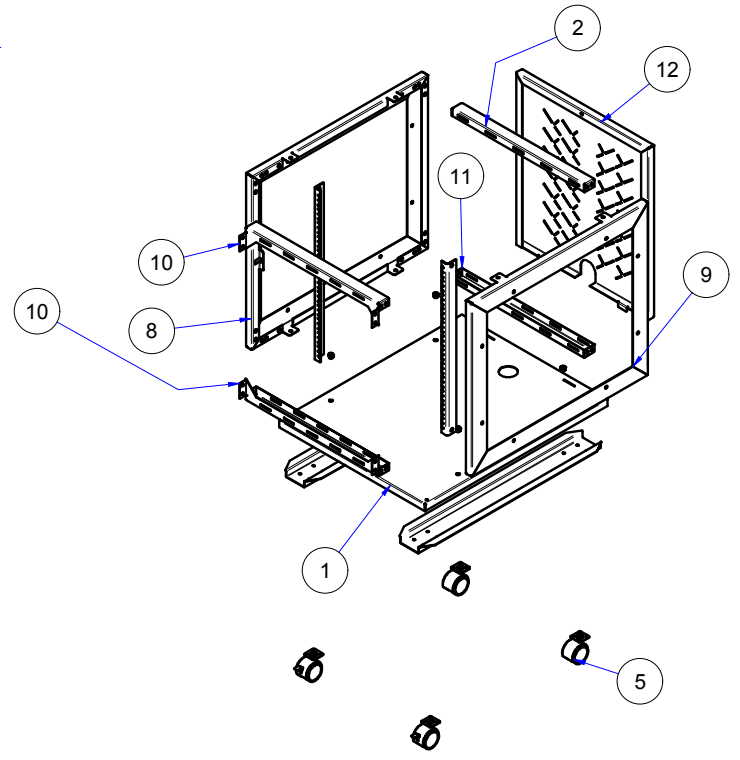

AVTEQ TOLERANCES Assemble Finished Product Finished Product: +/- 1.5 mm Welding Assemble Diagonals: +/- 1.5 mm Bend Final Measure: +/- 1 mm Punch Distance between centers: +/- 0.4 mm		CHANGE CONTROL DESCRIPCION / DESCRIPTION FECHA / DATE: _____ APROBO / APPROVED BY: _____ REALIZO / REALIZED BY: _____		NOMBRE PIEZA / PART NAME: ENSAMBLE CC-50 PROYECTO / PROJECT: PI0294 Rack gabinete CC-50 -12U Rack V01		VERSION No. 00 ESCALA / SCALE N.E.A.E.		 Furniture Engineered For Today's Technology
UNIDADES / UNITS mm		PESO / WEIGHT: N/A AREA: N/A		CANTIDAD / QUANTITY: 1 MATERIAL: N/A		FECHA / DATE: 09/04/2014		
DISEÑO / DESIGN BY: CRE		APROBO / APPROVED BY: HFRA		VERIFICO / VERIFIED BY: JLPG		EXCLUSIVE PROPRIETARY DRAWING OF AVTEQ, FULL OR PARTIAL REPRODUCTION IS PROHIBITED.		FDI-03-V4

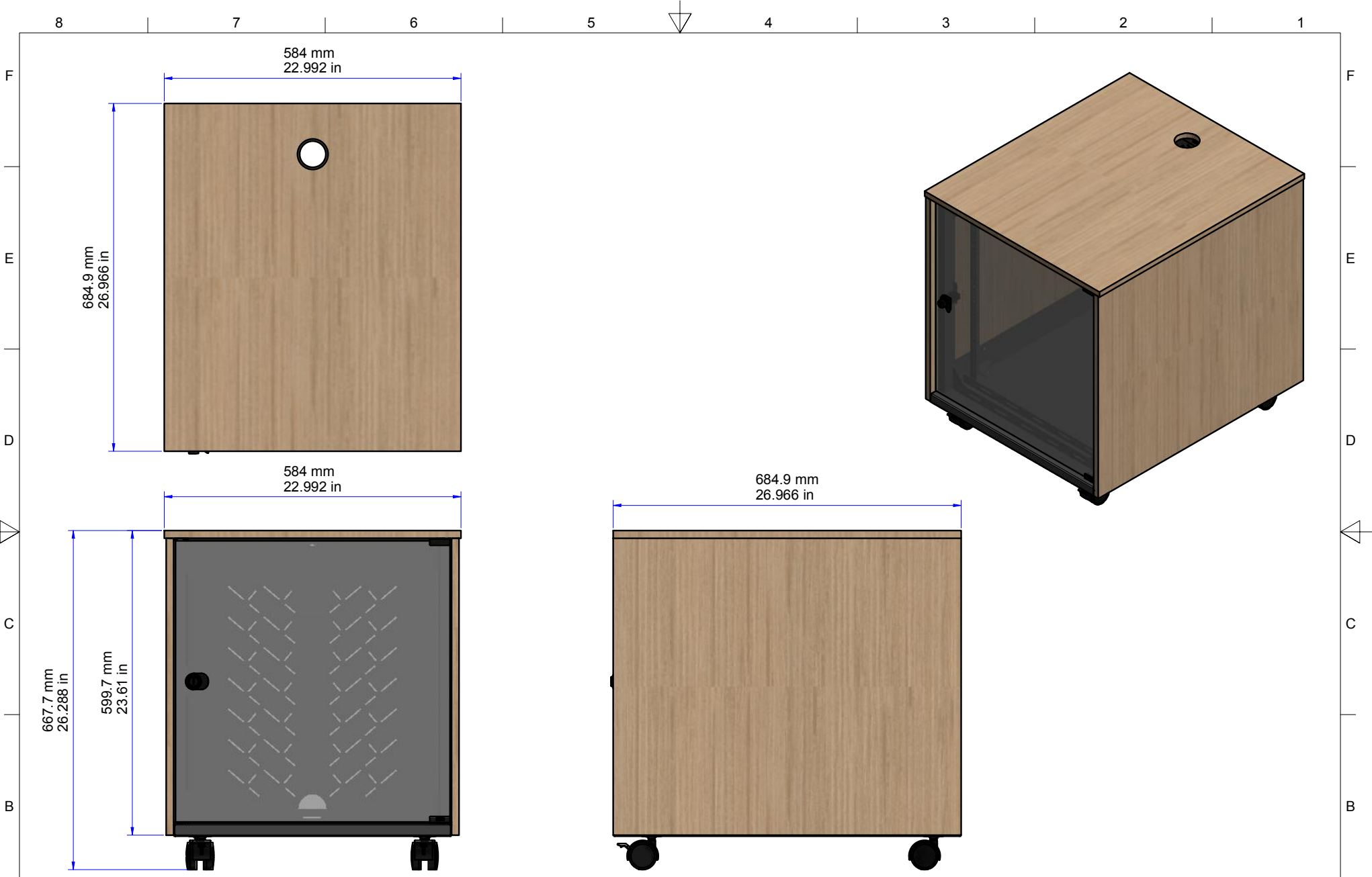

AVTEQ TOLERANCES	
Assemble Finished Product Finished Product: +/- 1.5 mm	
Welding Assemble Diagonals: +/- 1.5 mm	Final Measure +/- 1.5 mm
Bend Final Measure: +/- 1 mm	Bend Angle: +/- 1°
Punch Distance between centers: +/- 0.4 mm	Shears +/- 0.5 mm
PAG. No. 2/2	UNIDADES / UNITS mm

CHANGE CONTROL		
DESCRIPCION / DESCRIPTION		
FECHA / DATE:	APROBO / APPROVED BY:	REALIZO / REALIZED BY:
PESO / WEIGHT: N/A		AREA: N/A

NOMBRE PIEZA / PART NAME:			VERSION No.
ENSAMBLE CC-50			00
PROYECTO / PROJECT:			ESCALA / SCALE
PI0294 Rack gabinete CC-50 -12U Rack V01			N.E.A.E.
CANTIDAD / QUANTITY:	MATERIAL:	FECHA / DATE:	
1	N/A	09/04/2014	
DISEÑO / DESIGN BY:	APROBO / APPROVED BY:	VERIFICO / VERIFIED BY:	
CRE	HFRA	JLPG	

AVTEQ[®]
Furniture Engineered For Today's Technology

PI0294AA

EXCLUSIVE PROPRIETARY DRAWING OF AVTEQ, FULL OR PARTIAL REPRODUCTION IS PROHIBITED. FDI-03-V4