

# DynamiQ mCart II

## Motorized, height adjustable display cart

The DynamiQ mCart II provides motorized height adjustable capabilities. The double-column design provides the stability needed to work with large interactive touchscreens up to 98 inches.

The wired remote controller may be placed at a convenient and easy-to-reach location, allowing the user to adjust the height of the screen safely and quietly. The motorized stand has a dual anti-collision safety feature to prevent accidental pinching, when the system is moving and senses an obstruction it will stop and retreat. In its lowest position, the monitor allows easy access for users in wheelchairs.

A lockbox is located on the back of the VESA mounting box, which safely stores the electric controls. The lockbox also may be used for a mini PC or other small equipment.

With the optional accessories, the product may be equipped for use with a laptop or keyboard tray, teleconferencing equipment, camera, or soundbar.

### FEATURES

- Supports a single display up to 309 lbs.
- Motorized double columns provide height adjustable control
- VESA mounting box
- Rear lock box for storage or technology



AVT-487A11011



Front View



Back View

## DIMENSIONS

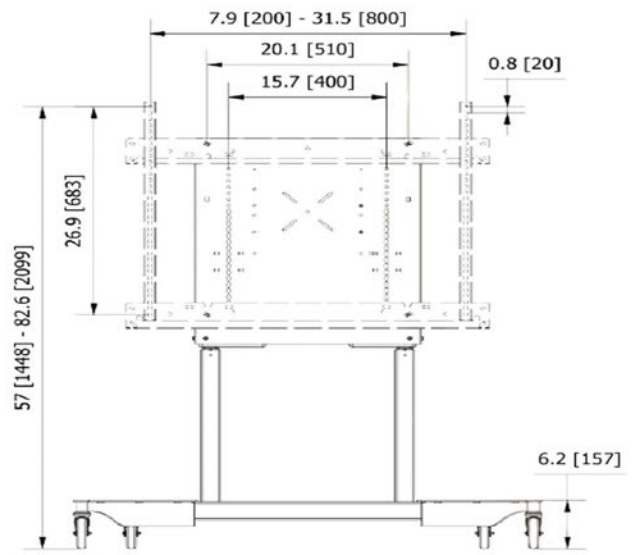
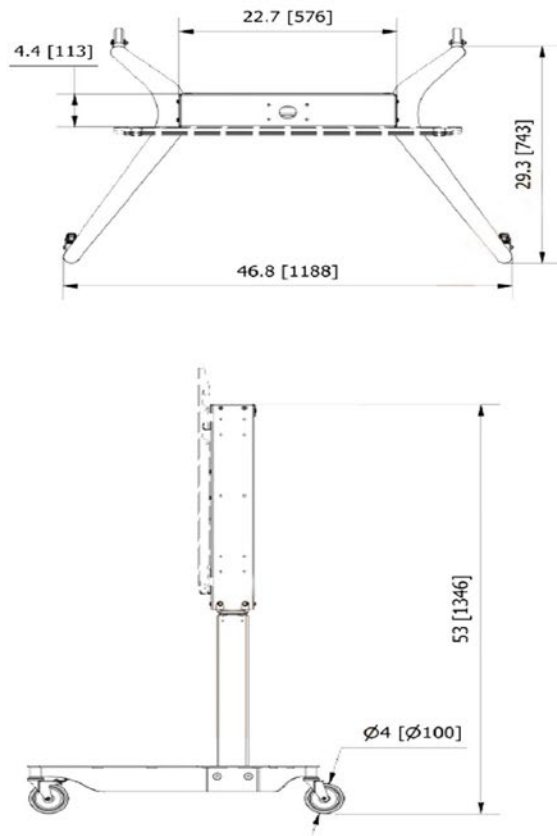

## SPECIFICATIONS

Part Number	AVT-487A11011
Display Sizes	Up to 98 inches
Dimensions (HxWxL)	
Cart	53 x 29.3 x 46.8 Inches (1346 x 743 x 1188 mm)
Vertical Adjust	25.6 inches
Load Capacity	309 lbs.

## ACCESSORIES



**Lockable Rear Cover**  
AVT-481A92



Call 800.285.8315 or visit [AVTEQ.net](http://AVTEQ.net)